

CLD
S+L

Download

DXF 2D
- 1220dfn.dxf



1223 Dafne LED

CORPS: en nylon f.v., incassable et auto-extinguible.
DOUILLE: en céramique avec contacts argentés. Culot E27.
CABLAGE: alimentation 220-240V 50/60Hz.
EQUIPEMENT: fourni avec base et embout à enterrer.
MONTAGE: en appli ou sur le sol.
NORMES: appareils conformes aux normes EN60598-1 CEI 34-21 en vigueur et présentant l'indice de protection IP65IK08 selon les normes EN60529. Double isolation.
LED: 15W = 100W INC 25000h - 860lm - 2700K

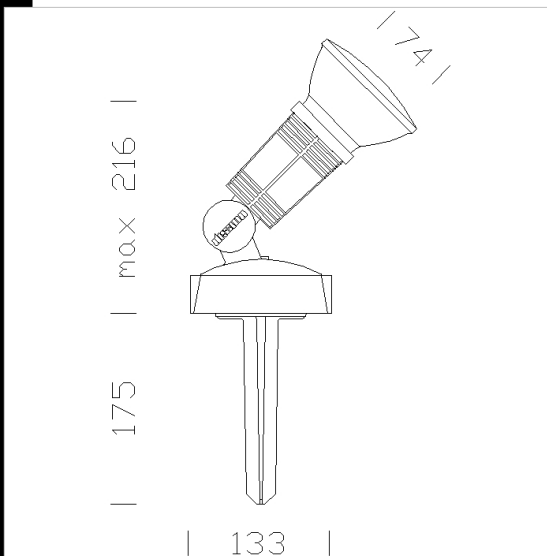

Code	Gear	Kg	Watt	Base	Lamps	Colour
431800-00	CLD CELL	1,00	LED PAR38 15W	E27	860lm-3000K - 25°-CRI80	NOIR

Accessori



- 118 étai



- 116 support angulaire



- 120 support pour poteau