



1616 Wall - with convex glass and stainless steel frame

Housing: In vandal resistant and V2 self-extinguishing polycarbonate, UV-stabilized, anti-yellowing.

Frame: In stainless steel

Reflector: Symmetric, in bright white UV-resistant polycarbonate. 40 W INC version, in polished aluminium.

Diffuser: In hemispherical impact resistant glass.

Painting: In several stages. First stage: black epoxy cationic electrocoating, upon chromate treatment, resistant to corrosive and saline environments. Second stage: UV-stabilizer priming, and lastly rough finish with grey acrylic coating.

Electric gear: 230 V/50 Hz power supply. Hard wire, 0.50 sqmm cross section and PVC-HT sheath. 2P polycarbonate terminal block, with maximum allowed lead cross section of 2.5 sqmm.

Standard supply: Complete with fixing frame. Standard recess box (to be cemented into the wall immediately after starting the works, while the frame can be applied at the end), with provision for power supply cable input on the bottom or from the sides, with reference points for plumb positioning in the recessed mounting.

Equipment: Silicone rubber gasket. Removable electric gear tray for easy maintenance. Cable gland in rubber.

Regulations: Produced according to applicable EN60598-1 CEI 34/21 standards, IP65IK08 degree of protection according to EN 60529 standards. Class of insulation II. They are provided with ENEC European certification.

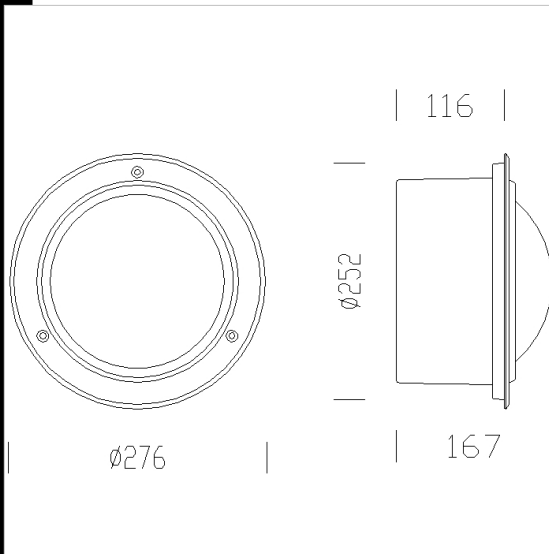

Code	Gear	Kg	Lumen-K-CRI	WTot	Colour
530680-00	CLD S+L	2.50	LED LAMP E27-800lm-2700K-CRI 80	0 W	STAINLESS STEEL

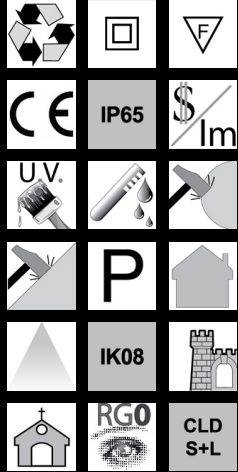

Download

DXF 2D
- 1616wall.dxf

Montaggi
- wall.pdf

The reported luminous flux is the flux emitted by the light source with a tolerance of $\pm 10\%$ compared to the indicated value. The W tot column indicates the total wattage absorbed by the system without exceeding 10% of the indicated