

CLD
S+L

Download

DXF 2D
- 1220dfn.dxf



1223 Dafne LED

Housing: in vandal resistant and self-extinguishing fiber glass nylon.
Lampholder: In ceramics, with silver-plated contacts. Socket E27.
Electric gear: 220-240V 50/60Hz power supply.
Equipment: Complete with base and ground spike.
Mounting: Wall or in the ground.
Regulations: Produced according to applicable EN60598-1 CEI34-21 standards, IP65IK08 degree of protection according to EN 60529 standards. Double insulation.
LED: 15W = 100W INC 25000h - 860lm - 2700K

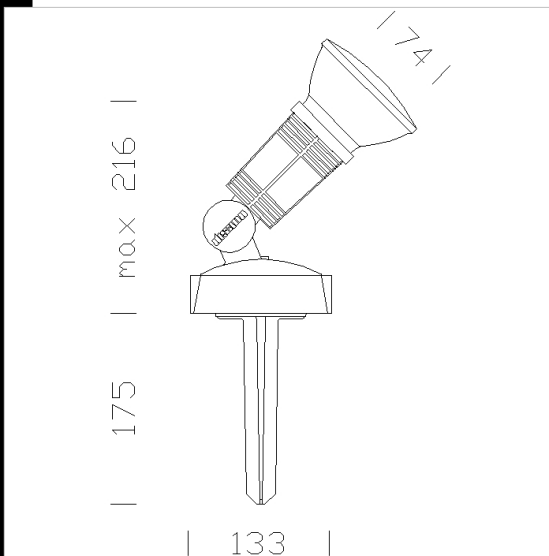

Code	Gear	Kg	Watt	Base	Lamps	Colour
431800-00	CLD CELL	1,00	LED PAR38 15W	E27	860lm-3000K - 25°-CRI80	BLACK

Accessori



- 118 clamp



- 116 corner support



- 120 pole mount