

1626 Box 2 LED - diffuser in scored matt polycarbonate

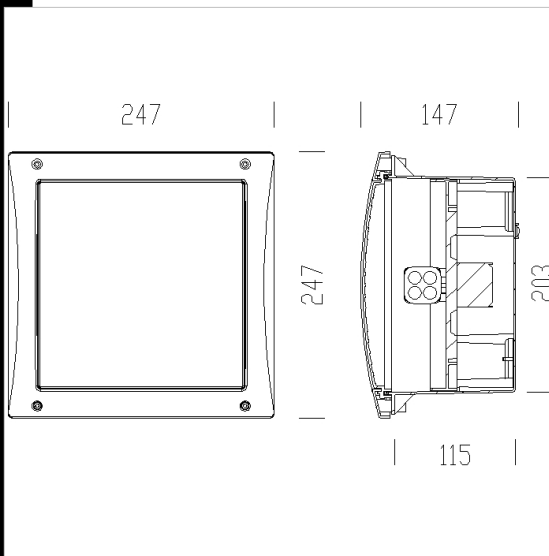

Housing: Square-shaped in f.g. nylon, grey (RAL 7035), vandal-resistant, UV-stabilized
 Frame: In UV-stabilized ASA, grey (RAL 7045)
 Diffuser: In vandal-resistant, V2 self-extinguishing polycarbonate, UV-stabilized
 Reflector: in bright white, vandal resistant, V2 self-extinguishing, UV-stabilized polycarbonate.
 Lampholder: In polycarbonate, with phosphor bronze contacts E27
 Electric gear: 230V/50Hz power supply. Hard wire, 0.50 sqmm cross-section. 2P terminal block with maximum allowed lead cross-section of 2.5 mm².
 Equipment: Rubber gasket. With polycarbonate gear tray
 Regulations: Produced according to applicable EN60598-1 CEI 34-21 standards, IP65IK08 degree of protection according to EN 60529 standards. This product can be installed on normally inflammable surfaces. Double insulation class.



Code	Gear	Kg	WTot	Colour
431640-00	S	1,30	0 W	GREY

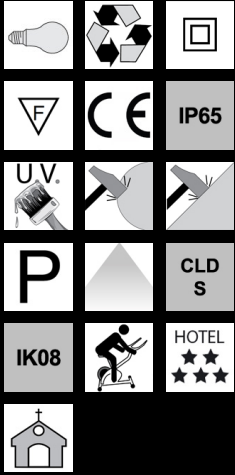

Download
 DXF 2D
 - d1626.dxf

The reported luminous flux is the flux emitted by the light source with a tolerance of ± 10% compared to the indicated value. The W tot column indicates the total wattage absorbed by the system without exceeding 10% of the indicated