

1758 Olbia 1

Housing/ Cap: in die-cast aluminium.
Diffuser: in shatterproof and self-extinguishing V2 polycarbonate, UV-stabilized, smooth on the outside and fluted on the inside.
Coating: the standard liquid immersion coating consists of a first metal surface pre-treatment stage, a successive epoxy cataphoresis corrosion and salt resistant coating, and a final layer of bi-component acrylic liquid UV-stabilised coating.
Equipment: Complete with 2.5 mm2 socket-pin connector

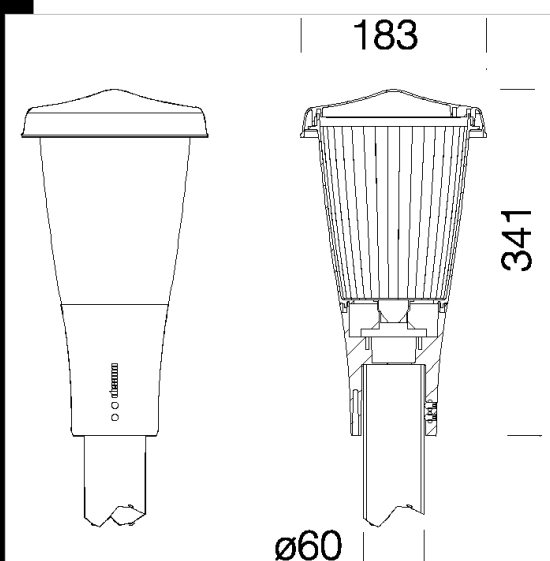

Code	Gear	Kg	Watt	Base	Lamps	Colour
424211-00	S+L	1.40	FLC 1x23EL	E27	1550lm-2700K-Ra 1b	GRAPHITE
424212-00	S+L	1.40	FLC 1x23EL	E27	1550lm-2700K-Ra 1b	GREEN
424210-00	S+L	1.40	FLC 1x23EL	E27	1550lm-2700K-Ra 1b	GREY9007

Pall



- 5 fiberglass pole

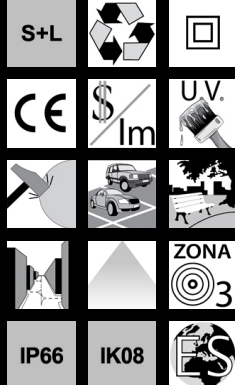

Download

- DXF 2D
- 1758.dxf
- 3DS
- disano_1758_olbia_1.3ds
- 3DM
- disano_1758_olbia_1.3dm
- Montaggi
- olbia.pdf