



## 2889 Saturno ø320 - narrow beam



Housing: in die-cast aluminium with cooling fins.  
 Optics: made of PMMA with high temperature resistance and UV rays.  
 Diffuser: 4mm thick tempered glass, resistant to thermal shocks and impacts.  
 Coating: the standard powder coating consists of a first metal surface pre-treatment stage and of single layer of UV-stabilised, corrosion and salt resistant polyester powder coating. On request: coating compliant with UNI EN ISO 9227 Corrosion tests in artificial atmospheres for aggressive environments. Equipment: complete with mounting bracket and graduated scale goniometer which allows for accurate pointing; external connector for quick installation. Safety insulating switch to cut off power during maintenance. Silicone rubber gasket; external screws and bolts in stainless steel; air recirculation valve. Electronic safety device to protect the LED module and the related ballast compliant with EN 61547. It works in two modes: - differential mode: surge between power cables and between the phase and neutral. - common mode: surge between power, L/N and ground cables or between the fixture's body if it is of class II and installed on a metal pole. Upon request: protection up to 10kV. Power factor:  $\geq 0.95$   
 Luminous flux maintenance 80%: 80000h (L80B10).  
 Wind surface: L:474cm<sup>2</sup> F:1286cm<sup>2</sup>.  
 Registered Design DM/100271

### Download

- DXF 2D  
- 2889i320.dxf
- 3DS  
- disano\_2889\_saturno\_72\_led.3ds  
- disano\_2889\_saturno\_168\_led.3ds  
- disano\_2889\_saturno\_120\_led.3ds
- 3DM  
- disano\_2889\_saturno\_72\_led.3dm  
- disano\_2889\_saturno\_120\_led.3dm  
- disano\_2889\_saturno\_168\_led.3dm
- Montaggi  
- saturno prj 07-20.pdf
- BIM  
- 2889 Saturno - narrow beam - 20200611.zip

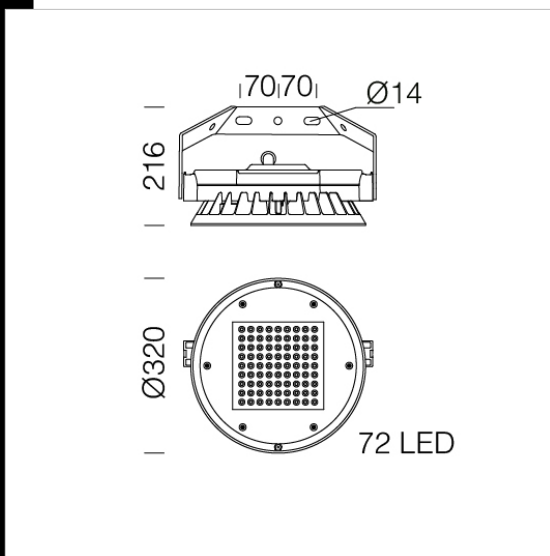

Code	Gear	Kg	Lumen Output-K-CRI	WTot	Colour	Surge
330870-00	CLD	8,61	LED-8427lm-4000K-CRI 80	67 W	GRAPHITE	6/8kV

### Accessori



- 26 protective guard 320mm



- 236 76mm pole mounting



- 235 60mm pole mounting

The reported luminous flux is the flux emitted by the light source with a tolerance of  $\pm 10\%$  compared to the indicated value. The W tot column indicates the total wattage absorbed by the system without exceeding 10% of the indicated