

1172 Argon LED COB

Housing: die-cast aluminium with wide cooling fins.
 Reflector: pressed prismatic aluminium, anodised (3μ) and polished for higher luminous efficiency.
 Diffuser: 5 mm thick, thermal shock and impact resistant protective tempered glass and vandal resistant.
 Standard supply: complete with IP67 airtight connector for mains connection.
 Ta-20+30°C. Luminous flux maintenance 80%: 50000h L80B20.
 Photobiological safety class: exempt group
 Class I and IP65-IK08 according to EN 60598-1.

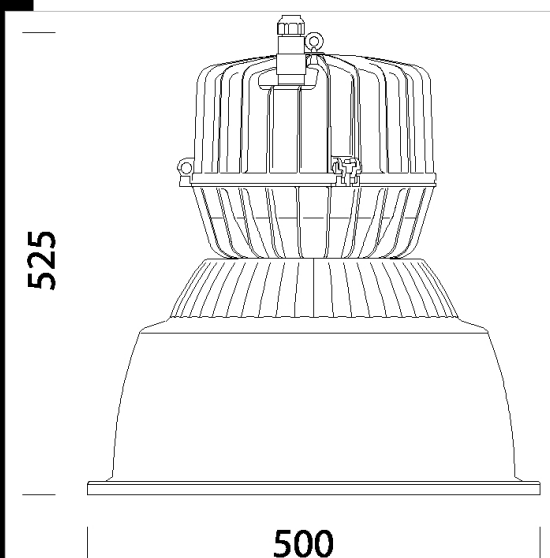

Code	Gear	Kg	Lumen Output-K-CRI	WTot	Colour
322652-00	CLD	7,16	LED COB-12129lm-5000K-CRI>70	129 W	GREY
322653-00	CLD	8,24	LED COB-10500lm-4000K-CRI 80	129 W	GREY

Accessori



- 1122 guard



Download

DXF 2D
- 1172i.dxf

Montaggi
- 1172_08-20.pdf

The reported luminous flux is the flux emitted by the light source with a tolerance of ± 10% compared to the indicated value. The W tot column indicates the total wattage absorbed by the system without exceeding 10% of the indicated