

## Gotham LED111

More and more frequently, exhibition areas involve an accurate selection of light, colour, equipment. The proper mix of these elements creates communication; but true entertainment begins with light. The settings, the colours and positions of displayed products may vary, but the lighting system is hardly ever adapted to every single change.

Housing: Die-cast aluminium with wide cooling fins.

Coating: Powder coated with UV-resistant polyester epoxy paint.

Standard supply: Only supplied with an aluminium bracket for attaching the base or the track mounting adapter.

Regulations: Manufactured in accordance with standards EN60598 – CEI 34 –21. Degree of protection in accordance with standards EN60529.

LED 32W - 3000K - 3300lm - 40° - CRI 83 - DIMM 1/10V

Luminous flux maintenance 70% 50000h (L70B50)

Power factor >0.9

Photobiological safety class: exempt group EN62471.

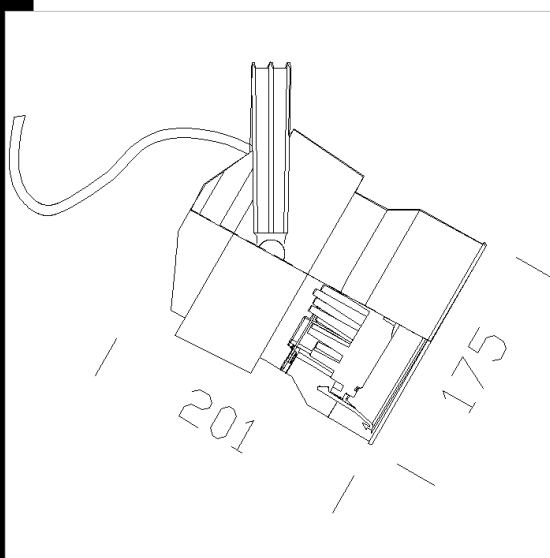

Code	Gear	Kg	Watt	Base	Lamps	Colour
22260374-00	CLD CELL-D	2,10	LED 111 32W		3300lm-3000K - 40°-CRI 83	SILVER

### Accessori



- Mechanical + power adapter



- Universal adapter +



- Base

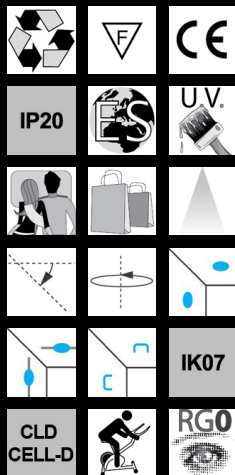

### Download

DXF 2D  
- 260074.dxf