

Compendio G1 - Fortimo 2000 SLM

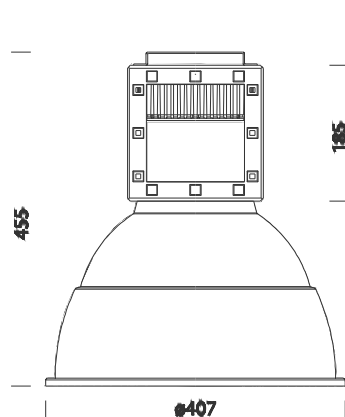

Code	Gear	Kg	Colour	Dimensions	lamp
22221279-00	CLD CELL	6.00	met. silver	0x0x455 Ø407	LED FORTIMO 2000-2000lm-3000K-CRI 80

In large areas and shopping centres, the light should be agreeable to the eye, and enhance the characteristics of the products on display. The reflector's design is also critical: it should be pleasant looking and blend harmoniously with the surroundings. These are the requirements we had in mind when we created the Compendio series.

Housing: Die-cast aluminium with cooling fins.

Diffuser: clear polycarbonate with a silk finish, metal-coated inside and painted outside.

Coating: Humidity resistant acrylic-resin liquid paint, UV-stabilised .

Regulations: Manufactured in accordance with standards EN60598 - CEI 34 -21. Degree of protection in accordance with standards EN60529.

Lamps: Includes discharge lamps, and compact fluorescent lamps.