

Corner 160 FORTIMO Integrated

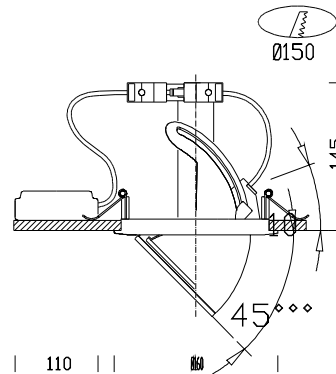

Code	Gear	Kg	Colour	Dimensions	lamp
22088070-00	CLD CELL	1.90	met. silver	0x0x145 Ø160	LED FORTIMO Integrated-675lm-3000k - 24°-CRI 80

Housing: in die cast aluminium

Coating: powder coating based on UV-stabilized acrylic resin chromate after treatment.

Equipment: Supplied with flush springs from 1mm up to 20mm

Regulations: Manufactured in accordance with EN 60598-1-CEI 34.21 standards. Degree of protection in accordance with EN60529 standards

LED: 675lm - 3000K - 24° - CRI80 - 25000h driver integrated