



## Stella - Dark office 65°

Housing: fixed downlight in die cast aluminium complete with spring clips for recessed mounting

Reflector: high-efficiency prismatic and polished aluminium.

Installation: Self LED is equipped with galvanised steel support brackets, with housing for springs for attachment to the false ceilings.

Painting: dust painted, using polyester epoxy paint to withstand UV rays.

Regulations: Manufactured in accordance with standards EN60598 – CEI 34 –21. Degree of protection in accordance with standards EN60529.

LED: 1000lm - 11W - 3000K - CRI>80 - DIM IGBT

Power factor: 0.9

Photobiological safety class: Exempt group.

Luminous flux maintenance 70%: 50.000h (L70B50).

recessed Ø 90/110mm

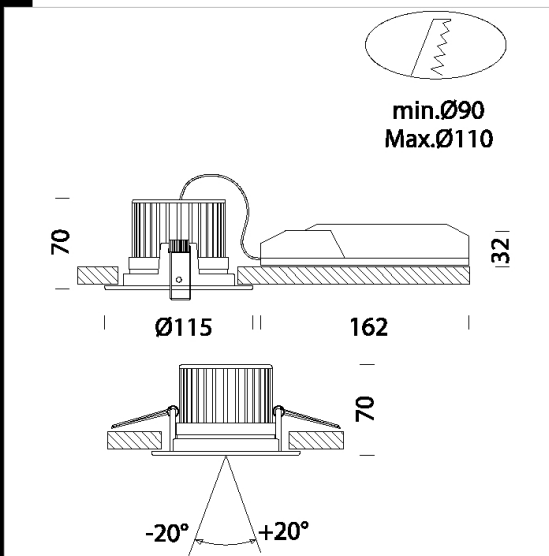

| Code        | Gear         | Kg   | Watt        | Base | Lamps               | Colour |
|-------------|--------------|------|-------------|------|---------------------|--------|
| 22067610-00 | CLD CELL-DI  | 0,50 | LED COB 11W | -    | 1000lm-3000K-CRI>80 | WHITE  |
| 22067610-09 | CLD CELL-D-E | 1,25 | LED COB 11W | -    | 1000lm-3000K-CRI>80 | WHITE  |

Download

DXF 2D  
- stella.dxf