



Download
DXF 2D
- ecomac.dxf

Eco Mac

A line of recessed spotlight made from die-cast zamak. With internal housing allowing installers to choose to mount the fixture flush with the ceiling or protruding, for greater control of the beam's direction (0° - 10°). Optionally these fixtures can be installed on shooks (step 100)

Housing: Die-cast zamak, with a steel bracket holding the terminal block. Includes springs for recessed mounting.

Lampholder: Ceramic with silver-plated contacts.

Coating: Humidity-resistant acrylic-resin liquid paint, UV-stabilised,. A different galvanic finishing process is used for chromium-plated and polished brass versions.

Regulations: Manufactured in accordance with EN 60598-1-CEI 34.21 standards. Degree of protection in accordance with EN60529 standards.

LED 500lm - 6W - 3000K - 38° - CRI 80

Power factor: 0.8

Luminous flux maintenance 70% 25000h (L70B50)

Photobiological safety class: exempt group EN62471.

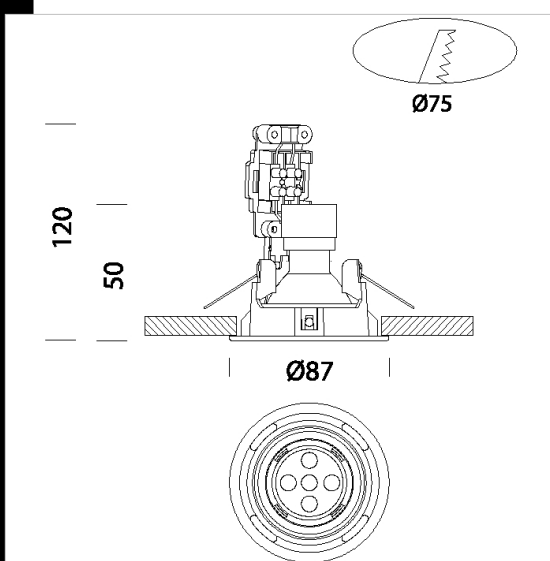

Code	Gear	Kg	Watt	Base	Lamps	Colour
22061014-00	CLD CELL	0,30	LED white 6W	GU10	450lm-3000K - 36°-CRI 80	WHITE
22061034-00	CLD CELL	0,25	LED white 6W	GU10	450lm-3000K - 36°-CRI 80	BLACK
22061074-00	CLD CELL	0,30	LED white 6W	GU10	450lm-3000K - 36°-CRI 80	SILVER
22061084-00	CLD CELL	0,30	LED white 6W	GU10	450lm-3000K - 36°-CRI 80	GOLDEN
22061064-00	CLD CELL	0,30	LED white 6W	GU10	450lm-3000K - 36°-CRI 80	CHROME
22061094-00	CLD CELL	0,30	LED white 6W	GU10	450lm-3000K - 36°-CRI 80	BRASS