

Minishop 2A

Housing: Steel plate.
 Coating: Humidity resistant acrylic-resin liquid paint, UV-stabilised.
 Regulations: Manufactured in accordance with standards EN60598 – CEI 34 –21. Degree of protection in accordance with standards EN60529.
 Power factor: 0.8
 Luminous flux maintenance 70% 15000h (L70B50)
 LED 7W - 520lm - 3000K - 36°

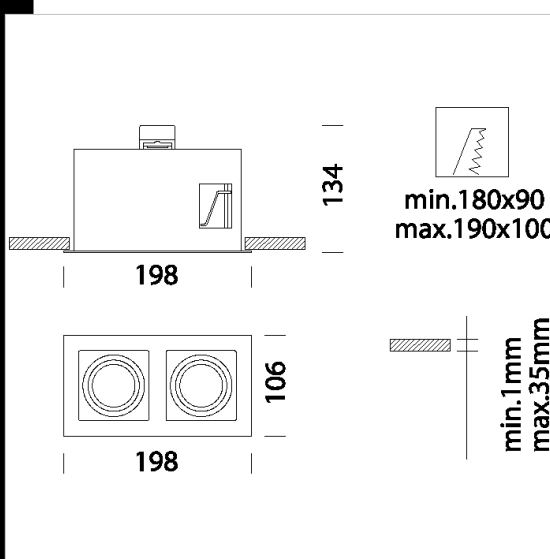

Code	Gear	Kg	Watt	Base	Lamps	Colour
182612-00	CLD CELL-D	1,00	LED white 7W	GU10	520lm-3000K - 36°-CRI 80	White



Download

DXF 2D
 - minishop2.dxf

Montaggi
 - atlas-beta-minishop.pdf