

965 Hydro ICE/HT - high/low temperature - LED



The high technological expertise achieved by the Disano Group in both the design and industrial manufacturing of lighting fixtures has resulted in the creation of a new watertight LED fixture. New Hydro LED features a modern design that blends well into any type of setting.

Housing: Injection moulded, in grey polycarbonate, vandal resistant, UV stabilized, high mechanical resistance due to the frame reinforced by internal ribbing.

Diffuser: injected moulded in polycarbonate with internal ribbing for greater lighting control, in V2 self-extinguishing, UV-stabilised material; its smooth outer finish makes cleaning easier and increases lighting efficiency. Equipped with stainless steel screw clamping. Reflector: in galvanised steel, previously stone-enamelled with UV-stabilised polyester resin. Clamping device manufactured directly onto the housing.

Dimensions: L 1260mm - 102mm - 120mm Standard supply: eco-friendly and anti-aging expanded polyurethane injected gasket. The fixing brackets for ceiling and suspension mounting are in stainless steel. Socket-plug connector. The fixture is secured to the fixing brackets through quick connectors. Regulations: manufactured in compliance with EN60598-1, EN60598-2-1. Degree of protection: pursuant to EN60598-1.

Power factor: >= 0.95 Luminous flux maintenance after 80.000 hrs: L80B20. Photobiological safety class: exempt

Low Flicker Risk Ambient temperature: -40°C a + 55°C On request: • with radar sensor for ON-OFF fixtures: subcode -19 (with default setting); • with pass-through wiring for continuous line mounting: subcode -0072; • with 1-10V dimmable electronic gear + emergency: subcode -94; • with emergency wiring with centralized power supply: sub-code -0050.

This lighting fixture meets the global standards of the International Food Safety (IFS), the British Retail Consortium (BRC) and the HACCP Directive regarding the safety of the lighting systems in the food industry.

In any case, it will be necessary to contact appointed designers and Disano's consultancy office to check the compatibility of materials with the food products processed and in all industrial environments where sanitizing systems are installed.

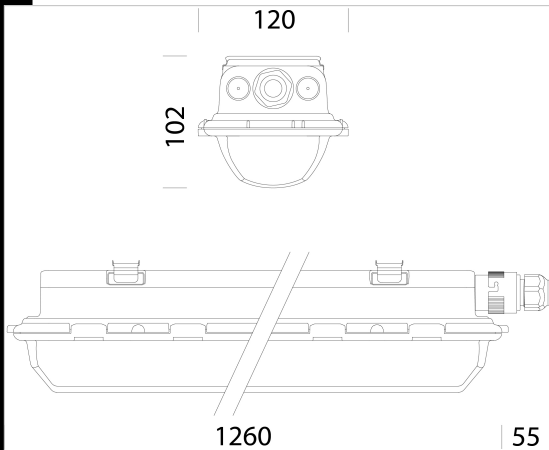

Code	Gear	Kg	Lumen Output-K-CRI	WTot	Colour
164780-00	CLD	1,95	LED-4992lm-4000K-CRI80	31 W	GREY
164781-00	CLD	1,95	LED-6989lm-4000K-CRI80	42 W	GREY

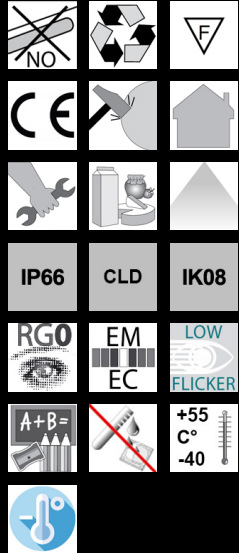

Download

DXF 2D
- 962.dxf

BIM

- 965 Hydro HT - High temperature -
20200214.zip

The reported luminous flux is the flux emitted by the light source with a tolerance of ± 10% compared to the indicated value. The W tot column indicates the total wattage absorbed by the system without exceeding 10% of the indicated